

Test setup to investigate the Ethernet frame transmission and reception timing when sending and receiving frames with a Xenomai application which replaces the Linux UEC driver:

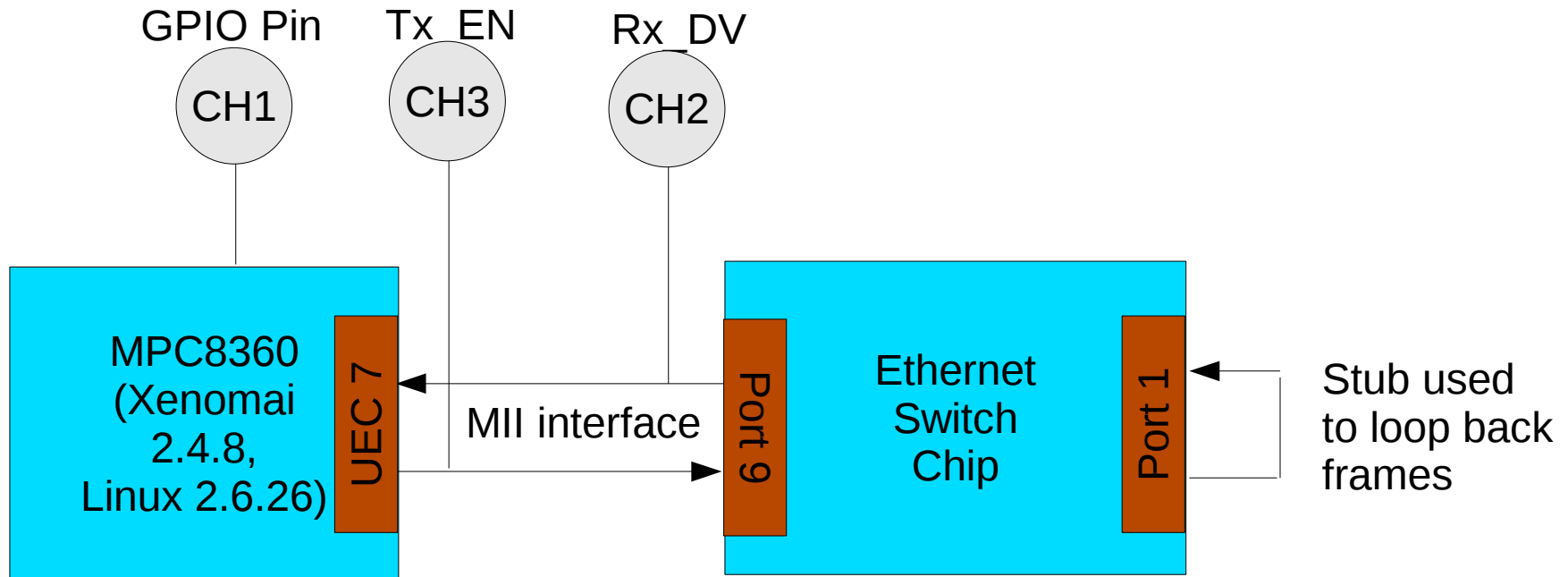

GPIO Pin ... is toggled when the UEC7 ISR is called

Tx_EN ... a signal of the MII interface which indicates when a frame is being sent out by UEC 7. The UEC 7 interrupt is trigger when this signal goes low.

Rx_DV ... a signal of the MII interface which indicates when a frame is being received by UEC 7. The UEC 7 interrupt is trigger when this signal goes low.